

Stealth Products[®]

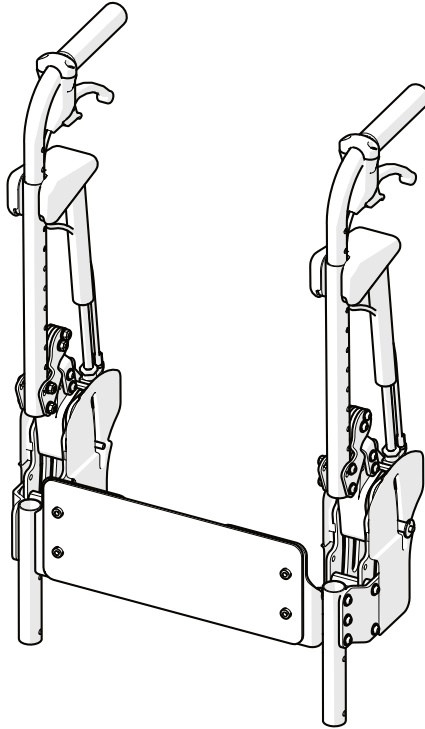

**Backs &
Support**



Effortless Postural Control (EpiC) Seating

Owner's Manual - Maintenance Guide

Effortless Postural Control - EpiC Seating



Table of Contents

Customer Satisfaction	i
Important Information.....	ii-iii
Warranty.....	ii
Supplier Reference.....	ii
Warning Labels.....	iii
Limited Liability.....	iii
Testing.....	iii
Design and Function	1-2
Parts Breakdown	1
Intended Use.....	1
Features.....	2
Installation Instructions	3-10
Preparations	3
Required Tools.....	3
Installation Plan.....	3
Before Installation	4
Installation.....	4-8
Removable Posterior Pelvic Support Installation	9
Back Support Installation	10
Adjustment Instructions.....	11-12
Posterior Pelvic Support Depth/Angle Adjustment.....	11
Actuator Cable Adjustment.....	12
Operating Instructions	13-14
Static Operation.....	13
Articulating Operation.....	14
Limiting Pin.....	14
Replacement Parts	15
Ordering Replacement Parts.....	15
WC-20 Transit Information	16-21
General Guidelines.....	16
Before Transit	16
Belt Placement.....	17-18
Trays.....	19
User Safety.....	19-20
First-Time Use.....	21
Dealer Assistance.....	21
User Testing	21
Conditions of Use.....	21
Care and Cleaning	22
Cleaning	22
Disinfection.....	22
Maintenance.....	22
Disposal.....	22

Stealth Products is committed to 100% customer satisfaction. Your complete satisfaction is important to us. Please contact us with feedback or suggestions to help us improve the quality and usability of our products.

You may reach us at:



Stealth Products, LLC

104 John Kelly Drive, Burnet, TX 78611

Phone: (512) 715-9995

Fax: (512) 715-9954

Toll Free: (800) 965-9229

Toll Free: (800) 806-1225

info@stealthproducts.com

www.stealthproducts.com



<p>EC REP</p> <p>MDSS GmbH Schiffgraben 41 30175 Hannover Germany</p>	<p>CH REP</p> <p>SODIMED SA Chemin Praz Devant 12 1032 Romanel sur-Lausanne Switzerland</p>	<p>UK Authorized Representative</p> <p>MDSS-UK RP 6 Wilmslow Road, Rusholme Manchester M14 5TP United Kingdom</p>
---	---	---

General

Read and understand all instructions prior to the use of the product. Failure to adhere to instructions and warnings in this document may result in property damage, injury, or death. Product misuse or failure to follow instructions will void the warranty.

Immediately discontinue use if any function is compromised, if parts are missing or loose, or if any component shows signs of excessive wear. Consult with your supplier for repair, adjustment, or replacement.

All persons responsible for fitting, adjustment, and daily use of the devices discussed in these instructions must be familiar with and understand all safety aspects of the devices mentioned. In order for our products to be used successfully, you must read and understand all instructions and warnings, and maintain our products according to our instructions on care and maintenance.

The installation instructions will guide you through this product’s options and possibilities.

Instructions are written with the expressed intent of use with standard configurations. They also contain important safety and maintenance information, as well as describe possible problems that can arise during use. For further assistance, or more advanced applications, please contact your supplier or **Stealth Products** at (512) 715-9995 or toll free at (800) 965-9229.

Always keep the operating instructions in a safe place so they may be referenced as necessary.

All information, pictures, illustrations, and specifications are based on the product information that was available at the time of printing. Pictures and illustrations shown in these instructions are representative examples and are not intended to be exact depictions of the various parts of the product.

Important Information



These products are designed to be fitted, applied, and installed exclusively by a healthcare professional trained for these purposes. The fitting, application, and installation by a non-qualified individual could result in serious injury.

Warranty

Our products are designed, manufactured, and produced to the highest of standards. If any defect in material or workmanship is found, Stealth Products will repair or replace the product at our discretion. Any implied warranty, including the implied warranties of merchantability and fitness for a particular purpose, shall not extend beyond the duration of this warranty. **Stealth Products** does not warrant damage due to, but not limited to: misuse, abuse, or misapplication of product, and/or modification of product without written approval from **Stealth Products, LLC**. Any alteration or lack of serial number, where applicable, will automatically void all warranty.

Stealth Products, LLC is liable for replacement parts only. **Stealth Products, LLC** is not liable for any incurred labor costs.

Stealth Products warrants against failure due to defective materials or workmanship:

Covers: 2 years
Hardware: 5 years
Electronics: 3 years

NOTICE

Any substitutions of supplied hardware will void the warranty. Misuse of items and "acts of nature" (e.g., flood, tornado) are not covered by the warranty.

In the event of a product failure covered by our warranty, please follow the procedures outlined below:

Call **Stealth Products** at (512) 715-9995 or toll free at (800) 965-9229.

Request a Return Authorization (RA) form from the Returns Department and follow the documentation instructions.



Additional warranty information may be found by visiting the website at <https://stlpro.site/returns-n-warranty>. Copies of this manual may be downloaded by accessing the Stealth website (<https://stlpro.site/stealth-docs>) and searching "P147D695" in the search bar at the top of the page.

Supplier Reference

Supplier:	
Telephone:	
Address:	
Purchase Date:	
Model:	

Warning Labels

Warnings are included for the safety of the user, client, operator, and property. Please read and understand what the signal words **DANGER**, **WARNING**, **CAUTION**, **NOTICE**, and **SAFETY** mean, and how they could affect the user, those around the user, and property.

 DANGER	Identifies an imminent situation which, if not avoided, may result in severe injury, death, and property damage .
 WARNING	Identifies a potential situation which, if not avoided, may result in severe injury, death, and property damage .
 CAUTION	Identifies a potential situation which, if not avoided, may result in minor to moderate injury and property damage .
NOTICE	Identifies important information not related to injury, but possible property damage .
SAFETY	Indicates steps or instructions for safe practices, reminders of safe procedures, or important safety equipment that may be necessary.

Limited Liability

Stealth Products, LLC accepts no liability for personal injury or damage to property that may arise from the failure of the user or other persons to follow the recommendations, warnings, and instructions in this manual.

Stealth Products does not hold responsibility for final integration of final assembly of product to end user. **Stealth Products** is not liable for user death or injury.

Testing

Initial setup and driving should be done in an open area free of obstacles until the user is fully capable of driving safely.

Design and Function

Parts Breakdown

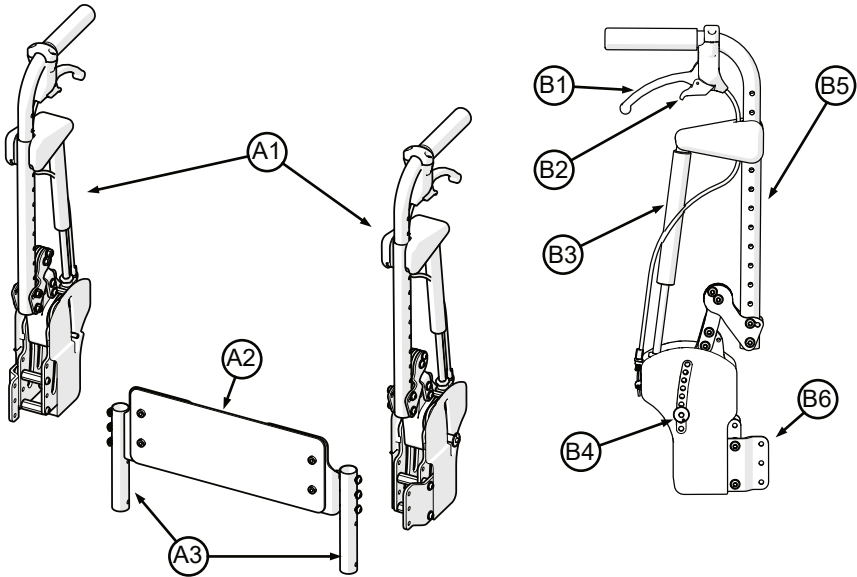

		Description	Qty
A	A1	Posterior Thoracic Support (L & R)	2
	A2	Posterior Pelvic Support	1
	A3	Adapter Tubes (ESCTUN-004 shown)	2
B	B1	Actuator Handle	2
	B2	Locking Lever	2
	B3	Strut	2
	B4	Limiting Pin	2
	B5	Back Support Tube	2
	B6	Mounting Plate	2

Intended Use

A system which, when added to an existing compatible mobility base, will provide segmented postural management for the end user. Support is provided in two anatomical segments: a fixed support at the pelvis and an articulating thoracic segment. Anatomically-appropriate adjustable pivot points and articulation paths create a system that significantly reduces shear force. Caregivers are able to lock the thoracic segment in a chosen position. By allowing the thoracic segment to move while actively supporting the pelvis, the system helps to maintain overall seating postures. Locking struts of various forces result in the system being available to end users who exhibit a wide range of tonal patterns.

Epic Seating is recommended for users of compatible mobility devices who require increased postural control while using the mobility device. Clinical indications include postural fatigue, thoracic hyper-kyphosis, sliding and seating tolerance

issues, dystonic and hypotonic users, breathing and/or digestion issues, and head positioning issues. Contraindications include spinal fusion of the thoracic-lumbar spine and spinal fractures.

The products discussed in this document are intended to be used as one component in the end user's overall seating and mobility equipment interventions and care regimens. An appropriately-qualified clinician with experience in seating and positioning should make the determination if this product is appropriate for the individual's specific seating requirement after evaluating the individual's overall medical condition and physical requirements.

Features

The Epic Seating System features:

- An adjustable, fixed pelvic support that helps maintain neutral pelvic positioning;
- A static (handles released) posterior thoracic support feature that supports the user at a selectable angle anywhere in the 14° range of motion;
- An articulating (handles locked) posterior thoracic support feature that moves with the user and absorbs force applied to it, returning to an upright position when that force is removed;
- Lateral thoracic support and head support may be attached to the thoracic support and will retain their position with the user's body during movement;
- Locking struts to selectively redirect forces that would otherwise cause stress and fatigue to the user and/or wheelchair;
- A posterior thoracic support that articulates around an "invisible" pivot point located in line with the user's pelvis. This reduces the number of moving parts that can come into contact with the user and cause abrasions or other injuries.
- A posterior thoracic support that maintains alignment with the user's spine and back, eliminating the slide inherent in articulating systems.
- The flexibility to utilize any of Stealth Product's back supports that fit 1-inch canes.
- The ability for caregivers and attendants to make adjustments to the user's seating position, without the use of tools, using two locking levers.
- The ability for the caregiver to address asymmetries by independently adjusting the thoracic and pelvic support as needed.
- A selection of resistance values for the locking struts, to accommodate user's specific requirements.

Installation Instructions

Preparations

Only a qualified service technician may install the Epic Seating System.

CAUTION

The use of improper tools may cause damage to the device. Any connection must always be secured with all delivered screws. Use only the screws included in the package.

WARNING

An incorrect installation of the Epic Seating System may cause damage to the hardware and/or injury to the user.

Required Tools

The tools needed to complete the installation are as follows:

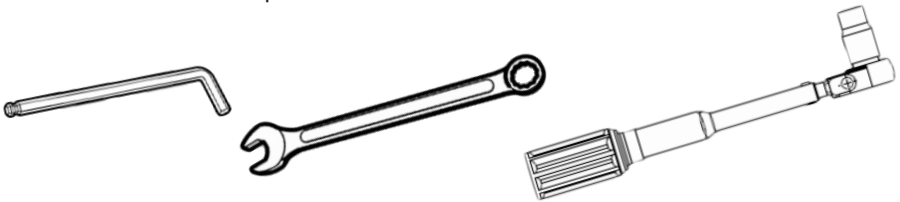

Hardware	Description
4mm Hex Key	Hex Key or T-Handle
Wrench	10mm Open or Box End, Crescent
Torque Wrench	ft/lb or N·m

Fastener	Torque
M6 x 1 x 45mm BHS	8.1 ft/lb (11 N·m)
M6 x 1 x 40mm BHS	8.1 ft/lb (11 N·m)
M6 x 1 x 25mm BHS	8.1 ft/lb (11 N·m))
M6 x 1 x 12mm BHS	8.1 ft/lb (11 N·m)
M6 x 1 NLN	8.1 ft/lb (11 N·m)

Installation Plan

Set up an installation plan before beginning the installation. This plan should take into account:

- The proper removal of the chair's back support canes in preparation for installation.
- Measurements of the user to establish configuration of the Epic Seating System.
- Distance from the seat cushion to the top of the user's iliac crest.
- Distance from the user's greater trochanter to the pivot assembly (*measured after thoracic support installation to determine final installation depth*)

Before Installation

1. Remove the back support, back support hardware, and back support canes from the existing chair frame. A chair-specific slipsheet will be included with the tube adapters for your model of chair.
2. The tube adapters should be installed on the cane mounts such that the heads of the screws face away from the center of the chair.

Installation

3. Remove the three nylon lock nuts and washers from the button head screws on the adapter tubes. The adapter tubes contain a tube nut specific to the chair model. Three of the holes are used to secure the pivot assembly mounting bracket to the adapter tube.

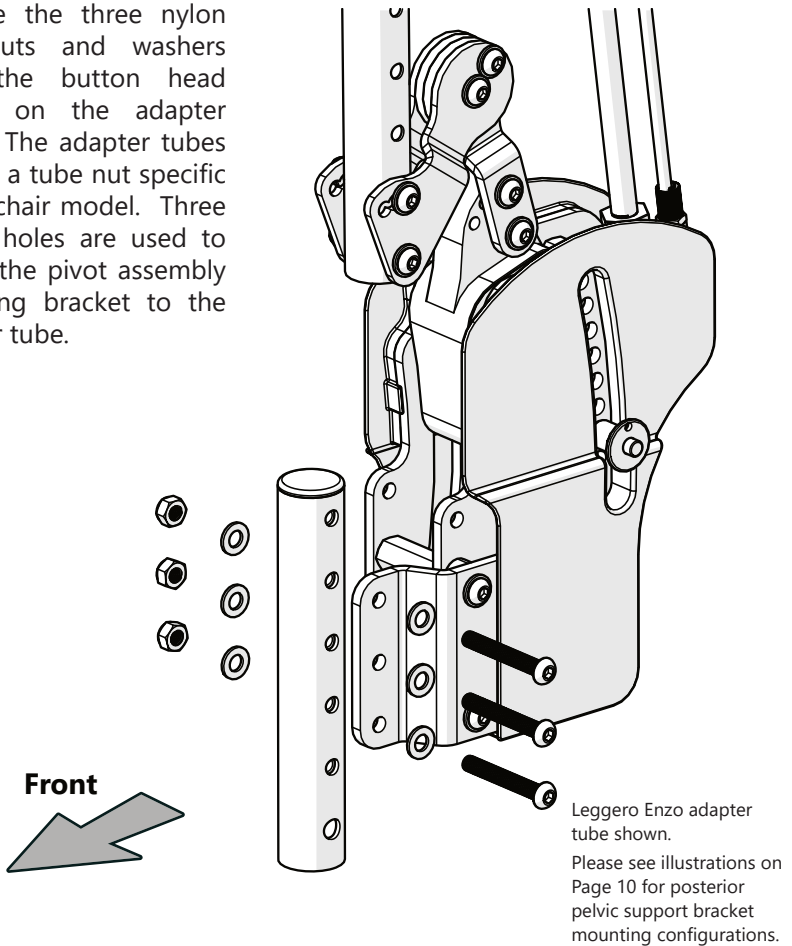

Installation Instructions

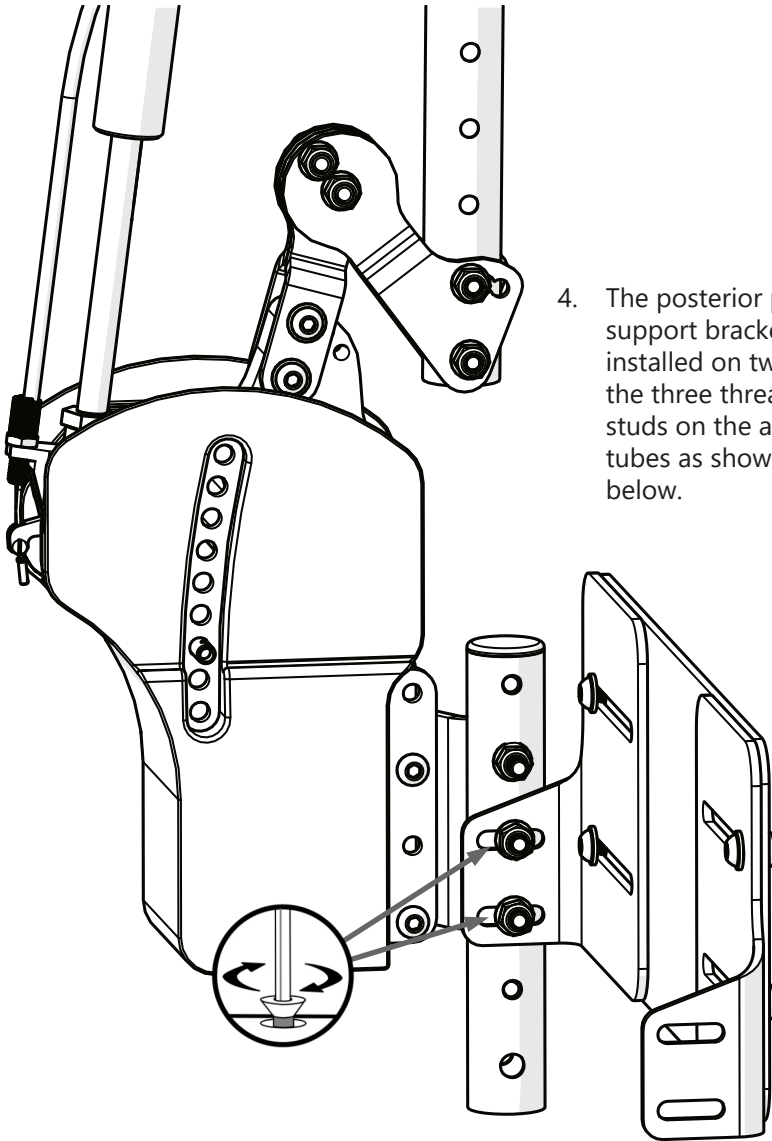

4. The posterior pelvic support brackets are installed on two of the three threaded studs on the adapter tubes as shown below.

Install the posterior pelvic support brackets on the set of studs that align the top of the pad with the top of the user's pelvis (between the PSIS and iliac crest). The position chosen for placement of the posterior pelvic support will determine which screws will be used to mount it.

- Center the posterior pelvic support plate on the posterior pelvic support brackets using the four (4) button head screws provided. Torque the screws to the specifications listed on Page 3.

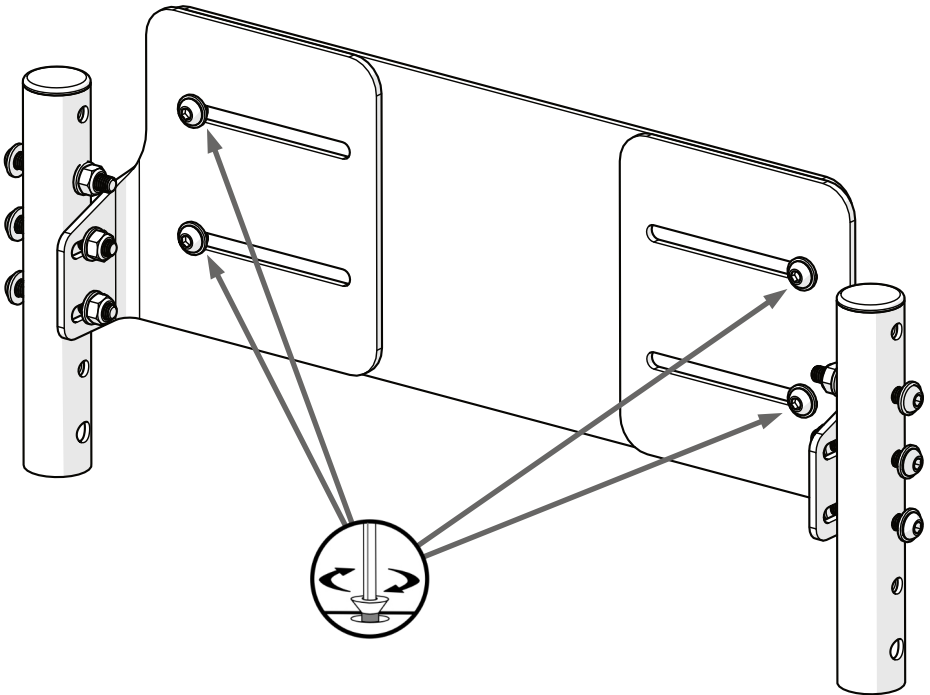

TIP:

The posterior pelvic support may be rotated 180° top to bottom from the position shown in the picture to allow for a lower positioning.

Installation Instructions

- Adjust the depth of the pivot assembly so that the distance between points (A) and (B) is as close to 9 inches as possible. Adjustments are in increments of one inch. To adjust the mounting plate, remove the two (2) screws securing each side to the adapter tubes and move the pivot assemblies to the new position. Torque the screws to the specification listed on page 3.

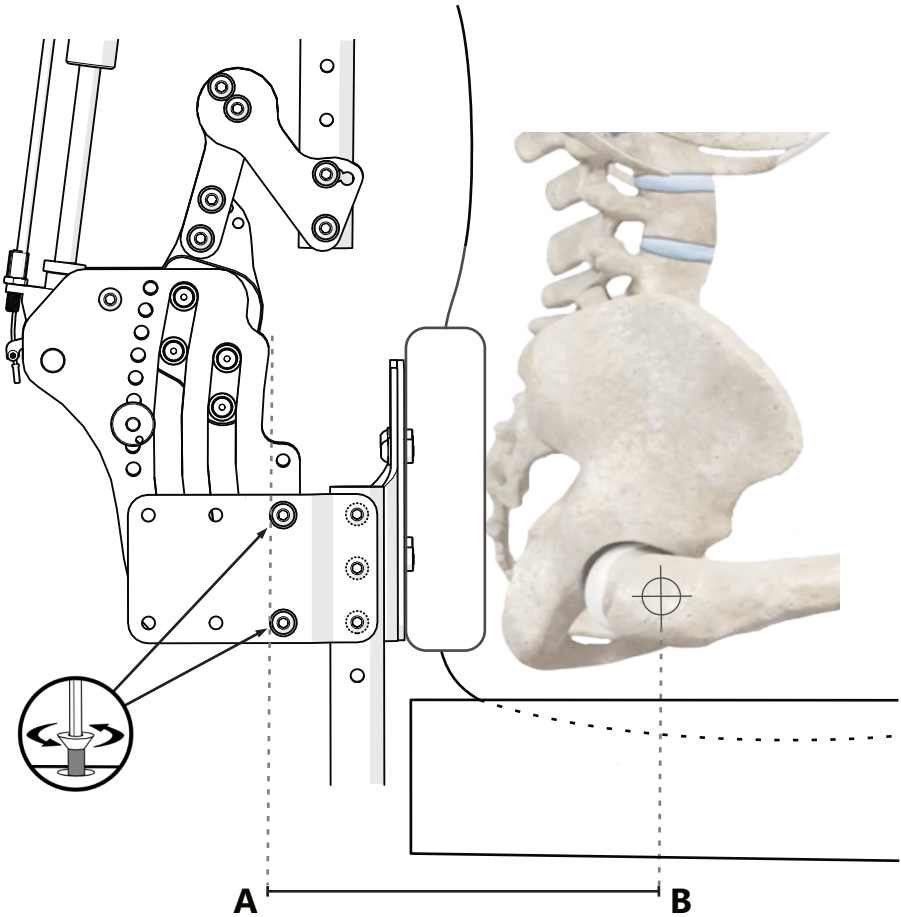

- Refer to the images and instructions on the next page to ensure the upper cane position correlates with the position chosen for the pivot assembly.

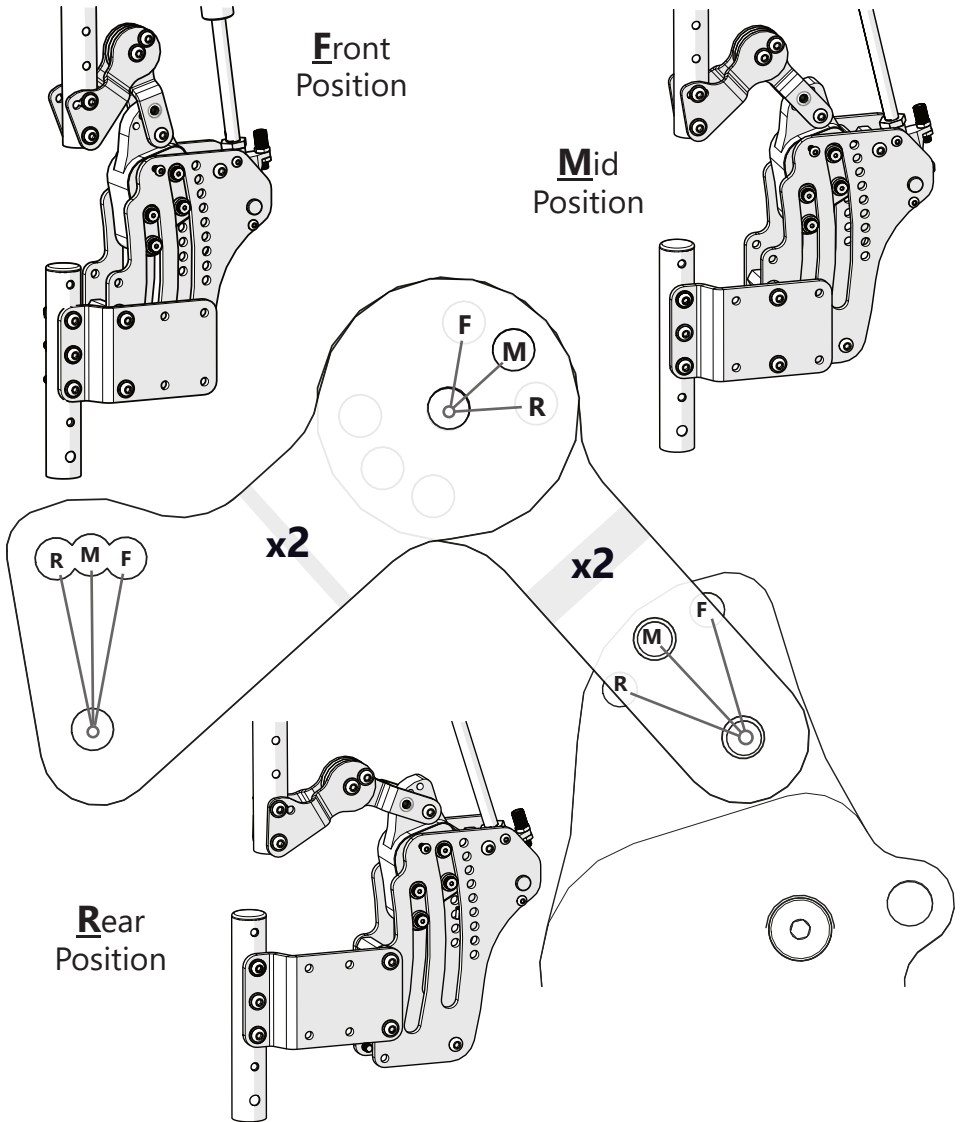

If the position of the pivot assembly on the mounting plate needs to be changed, the angle and position of the backrest tubes will require adjustment to match. To adjust these joints, loosen the screw in the pivot hole of the part and remove the other screw. Choose the proper alignment holes, based on the depth chosen for the pivot assembly. Insert the screw, and tighten to secure it in the new position. (**F** = Front, **M** = Mid, **R** = Rear) Refer to the chart on Page 3 for proper torque specifications.

Removable Posterior Pelvic Support Installation

1. Install the mounting brackets on the left and right attachment tubes as shown in the illustration. Tighten the nuts just enough to hold the mounting angles in similar positions.

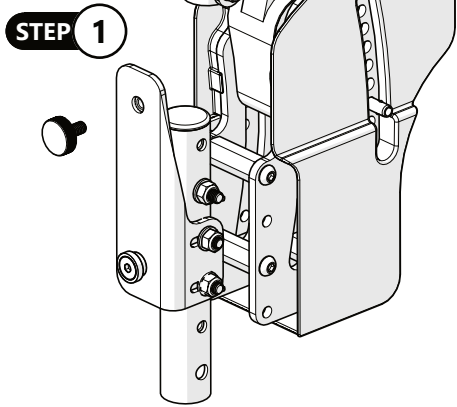

Bracket may be mounted at different heights, based on the needs of the user, as detailed on Page 12.

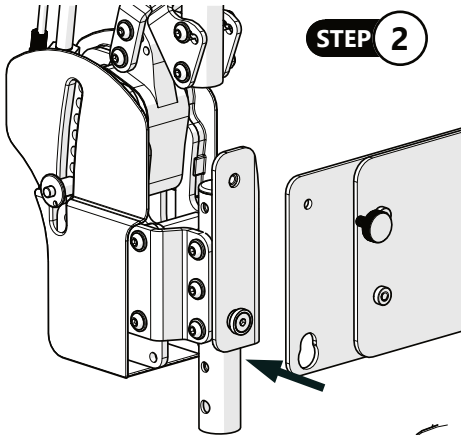

2. Slide the side plates over the bushings and line up the top screw holes with the threaded adapters in the mounting brackets.

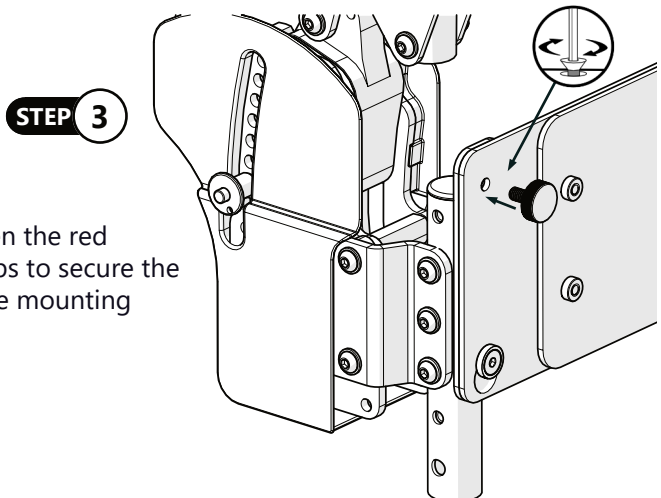

3. Insert and tighten the red attachment knobs to secure the side plates to the mounting brackets.

Installation Instructions

- Place the center plate in front of the side plates and align the threaded holes with the slots in the side plates as shown to the left.

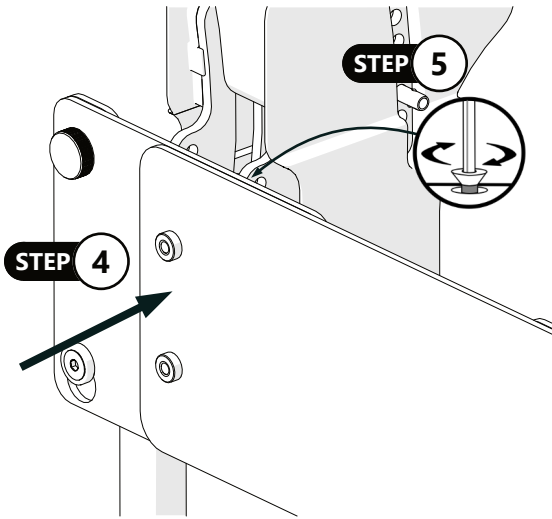

- Thread four M6 x 1 x 12mm button head screws with four M6 washers through the slots in the side plates and into the threaded adapters on the center plate. Adjust the center plate to the right or left to center it evenly on the assembly. Tighten the screws to secure it in position. Torque the screws to the specifications found on Page 3.

- Affix the posterior pelvic cushion to the posterior pelvic plate (cushion not shown in illustration).
- Adjust the final angle and depth and torque the nuts holding the mounting brackets to the attachment tubes to the values specified on Page 3.
- Temporary removal of the posterior pelvic support and cushion is achieved by removing the two red knob screws and lifting the plate and cushion up and off the mounting brackets.

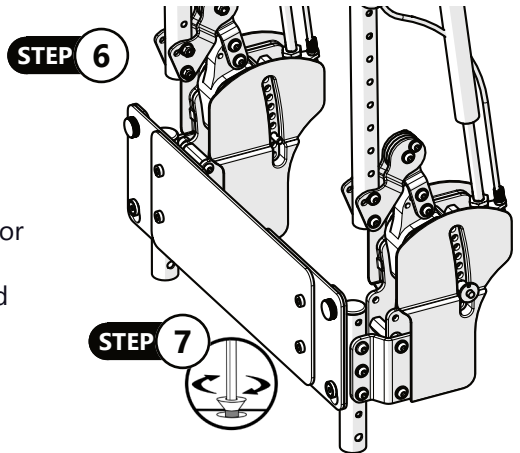

Back Support Installation

Installation of a back support to the Epic Seating system is similar to installing most of Stealth's back supports on a manual wheelchair. Follow the instructions included with your back support and hardware. The space between the bottom edge of the back support and the top edge of the pelvic support after installation should be equal to roughly the thickness of your hand. If the back support contacts the pelvic support during articulation, raise the back or lower the pelvic support a sufficient amount to avoid impingement of the cushions or supports.

Posterior Pelvic Support Depth/Angle Adjustment

The posterior pelvic support may be adjusted approximately 3/4" to fine tune its depth, according to the user's positioning needs. The fixed pelvic support is shown below. The instructions are the same for the removable pelvic support.

Initial adjustment of depth is set during the installation of the uprights to the seat frame, in order to define and preserve the center of gravity. Subsequent fine adjustment may be made to the posterior pelvic plate after the initial depth is finalized.

To adjust the posterior pelvic support:

1. Loosen the four (4) nuts securing the pelvic support to the adapter tubes.

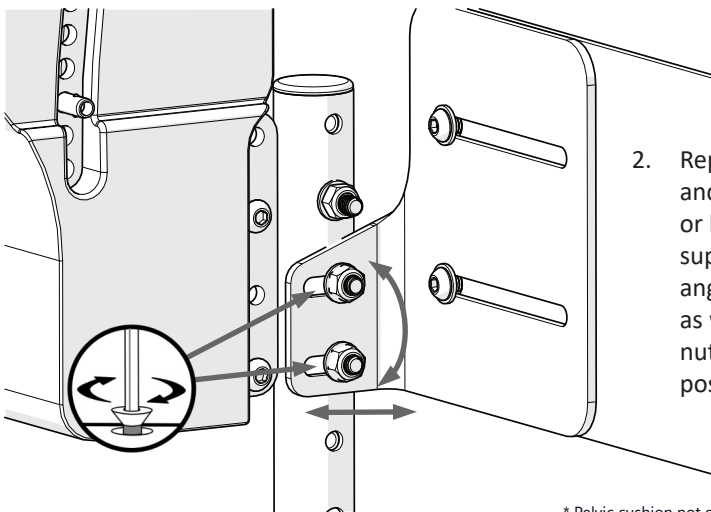
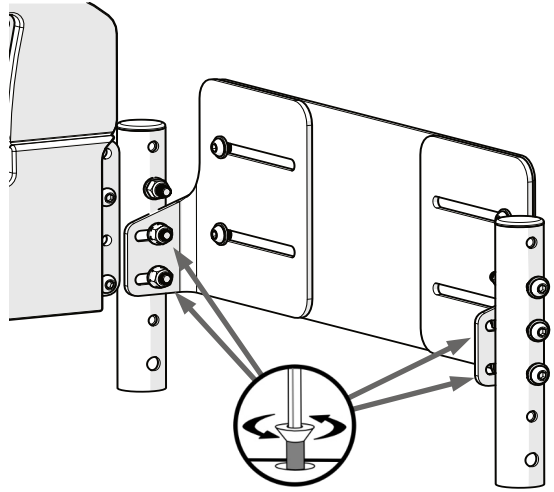

2. Reposition the support and cushion* forward or backward. The support and cushion angle may be adjusted, as well. Tighten the nuts to secure it in position.

* Pelvic cushion not shown in illustration.

NOTICE

Be sure to adjust the back support accordingly each time the posterior pelvic support is adjusted.

Actuator Cable Adjustment

The Actuator Cables connect the control handles on the hand grips to the Strut Actuator Arms, which open and close the valves that lock or unlock the strut. The cables should be checked as part of regular maintenance to ensure proper operation.

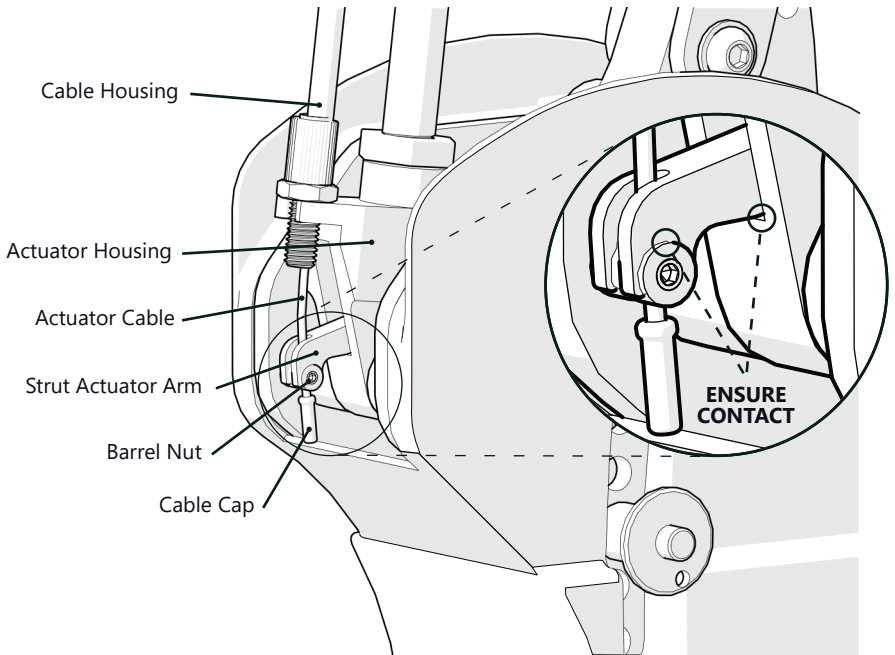

To adjust the tension of the Actuator Cables:

1. Check that the Actuator handles on the hand grips are unlocked and in the lower, open position.
2. Visually inspect the space between the Strut Actuator Arm and the Barrel Nut. The Barrel Nut should be in contact with the Strut Actuator Arm without lifting the Strut Actuator Arm from its position in the bottom of the Actuator Housing.
3. If the actuator handle on the hand grip is in the lower position, and there is a gap between the Barrel Nut and the Strut Actuator Arm, loosen the screw in the Barrel Nut. Pinch the Actuator Cable between the Cable Cap and Barrel Nut and gently pull the Actuator Cable through the Barrel Nut until it touches the Strut Actuator Arm. Tighten the Barrel Nut to secure it to the Actuator Cable.
4. Inspect the Strut Actuator Arm for contact with the Actuator Housing. If the Strut Actuator Arm in the lower position is in contact with both the Actuator Housing and the Barrel Nut (as shown in the circle above), the cable has been properly tensioned.
5. Squeeze the actuator handle on each hand grip to ensure proper operation of the Actuator Cable and Strut Actuator Arm.

Static Operation

Static operation works by releasing the locks on the strut handles (grip levers). When the levers are unlocked, the strut's valves are closed and will not allow movement in response to user input. Static operation may be activated at any point in the 14° range of motion and will maintain this position until reset.

Depending on the back support and hardware installed, the left and right pivot assemblies may be adjusted at differing angles.

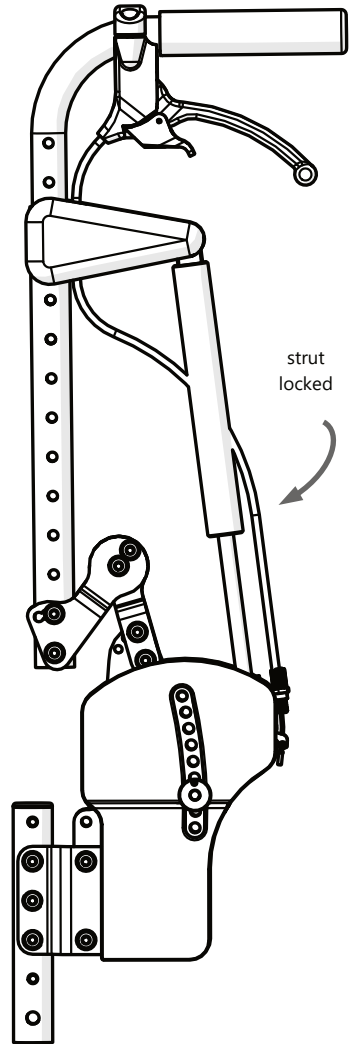
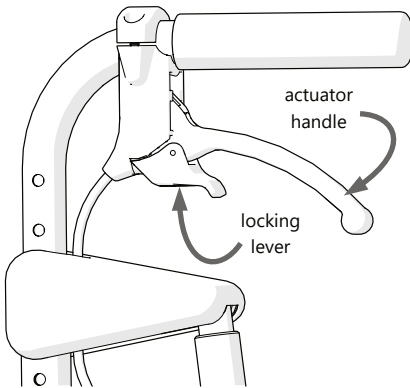

CAUTION

Manually test the resistance of the struts on a regular basis. Loss of or reduced function in one or both of the struts will cause lack of support for the user. If the struts should lose function, contact your supplier to obtain a replacement.

WARNING

Exercise caution when activating the articulating operation of the **Epic Seating** system. If the chair is sitting on an incline, or tilt has been applied to the chair, the efficacy of the back support to return the user to an upright position will be reduced. Use articulating operation **ONLY** in an upright position.

Articulating Operation

Articulating operation is achieved by engaging and locking the levers on the push handles, opening valves in the struts that allow them to retract and extend. The levers may be engaged momentarily to manually adjust the static angle of the seating system, or they may be locked in the open position to allow the back to respond to user input actively.

The posterior thoracic support is allowed to pivot to the rear up to 14°, while the posterior pelvic support remains fixed, maintaining the position of the pelvis. This operation mitigates the effects of movement that would otherwise impact the chair and/or the user. Head and lateral support hardware retains alignment with the user.

WARNING

Do not hang backpacks or other devices or gear which will add weight to the articulating portion of the back support, as this will reduce the effectiveness of the back support to respond to input forces.

Limiting Pin

The limiting pin is used to limit the range of motion during articulation. The bearing block has a through-hole that allows the pin to lock the back support in place. The limiting pin can be placed above, or below, this through-hole to limit the range of return, or articulation, respectively.

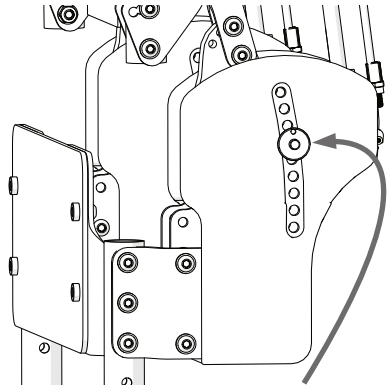
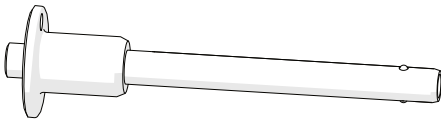

Limiting pin set to reduce range of extension by approximately 60%.

CAUTION

The strut is designed to return the user to an upright position. Extra weight attached to or hanging from the hand grips or back may overload the strut and inhibit its ability to return the user to an upright position.

NOTICE

In the event of strut failure, the limiting pin may be placed in the through hole of the bearing block to temporarily provide static support for the user.

Replacement Parts

Ordering Replacement Parts

Specific replacement parts can be ordered to replace worn or broken parts. Contact your dealer or Stealth Products to request the parts listed below for the Epic Seating System.

Item	Description	Part Number
Release Pin	Push-Button Quick-Release Limiting Pin	<i>ESR0001000</i>
Bearing Set	Set of Eight (8) Bearings and Shoulder Bolts, for Single Strut Assembly	<i>ESR0002000</i>
Gas Spring, 50N, Gas Spring, 100N	One (1) Replacement Gas Spring, 50N or 100N One Upper Plastic Strut Assembly Cover	<i>ESR0003050, ESR0003100</i>
Cable Assembly	One (1) Set, Strut Control Handle, Cable, and Housing w/Barrel Clamp, Adjuster Screw, Ferrule, and End Cap.	<i>ESR0004000</i>
Foam Grip	One (1) Foam Grip	<i>ESR0005000</i>
Lateral Pelvic Wedge	Set of Two (2), Lateral Pelvic Pad Wedge	<i>ESR0006000</i>
Pelvic Pad Cover	Replacement Cover for Pelvic Pad, No Foam	<i>ESR00070XX, XX = 10" - 22"</i>
Pelvic Pad	Replacement Pelvic Pad	<i>ESR00080XX XX = 10" - 22"</i>
Cable Guide, 50N Cable Guide, 100N	Replacement Cable Clamps (2), Black (50N), Dark Grey (100N)	<i>ESR0009050, ESR0009100</i>
Strut Assembly Covers	Upper and Lower Plastic Strut Assembly Cover	<i>ESR0010000</i>

General Guidelines

- Attach the tie-down straps only to the designated labeled transit security points.
- Tighten the straps sufficiently to remove all slack. Never attach tie-downs to adjustable, moving, or removable parts of the wheelchair.
- Position the anchor points for the rear tie-down straps directly behind the rear securement points on the wheelchair.
- The front tie-down straps should anchor to floor points that are spaced wider than the wheelchair to provide increased lateral stability.

CAUTION

The WC20-approved Epic Seating System should only be used as described in the manufacturer's instructions.

Before Transit

- Clients who use wheelchairs should transfer to the vehicle seat and use the vehicle-installed occupant restraint systems
- Prior to transporting, always double-check the tie-downs and hardware.
- On tie-downs and restraints, look for tears or worn webbing straps. Replace torn or worn webbing straps as necessary.
- Look for damaged hooks or loose tie-down hardware.
- On the seating system, check for loose screws attaching the hardware to the back. Check for loose screws attaching the hardware to the seat. These should be snug and not over-tightened.

DANGER

The WC20 approved Epic Seating System is designed specifically for occupancy when used on wheelchairs that are facing forward in motor vehicles.

WARNING

The limiting pin should be installed in the hole that passes through the bearing block during transportation, locking out the ability of the back support to respond to force. The system may respond to heavy acceleration by allowing the user to articulate backwards, possibly reducing the effectiveness of belt restraint systems.

Belt Placement

- The pelvic belt restraint should be worn low, across the front of the pelvis near the junctions of the pelvis and the thighs.
- The belt restraint buckle of three-point belt restraints should be placed in contact with the occupants body and away from wheelchair components.
- The junction of the shoulder belt and pelvic belt of three-point-belt restraints should be located near the hip opposite the shoulder over which the diagonal belt crosses and not near the midline of the occupant.

Proper Positioning of Belts on Occupants

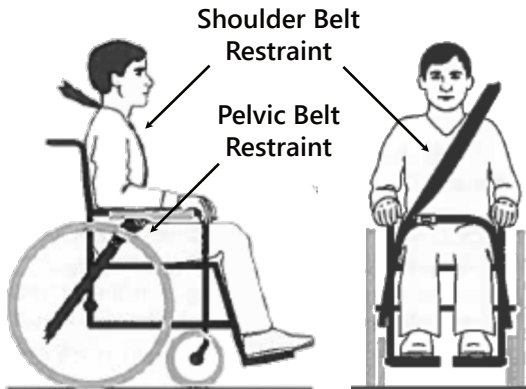

- Upper torso belt restraints should fit directly over, and in contact with, the middle of the shoulder.

CAUTION

Belt restraints should be adjusted to fit as snugly as possible, consistent with user comfort.

SAFETY

Belt restraints should be positioned on the wheelchair occupant in accordance with WTORS manufacturer instructions.



Belt restraints should not be routed outside of the wheelchair, over the wheelchair wheels, or over the wheelchair arm supports and should not be held away from the body by wheelchair components or parts.

SAFETY

Belt restraints should not be worn twisted or in a manner that reduces the area of contact of the belt webbing with the occupant.

Both pelvic belt and shoulder belt restraints that comply with RESNA WC-4:2012, Section 18 and/or 4.6, 5.2, 5.3 of RESNA WC-4:2012, Section 19 should be used to limit occupant movement in a crash and reduce the likelihood of occupant ejection from the vehicle and/or injurious contact of the occupant with the vehicle interior. The pelvic belt should be angled between 30° to 75° horizontally when viewed from the side, and ideally between 45° to 75° horizontally, as shown in the figure to the right.

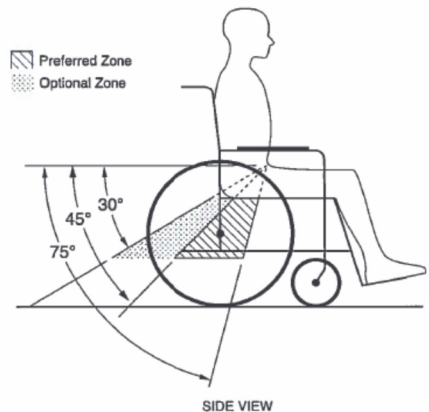

WARNING

Back supports with adjustable recline angles should not be tilted back more than 30° to the vertical during travel in vehicles unless necessary for the medical and postural needs of the occupant.



WARNING

If the back support must be adjusted to an angle that is greater than 30° to the vertical during travel, the upper shoulder-belt anchor point should be adjusted rearward to maintain belt contact with the wheelchair occupant's shoulder and chest.

Trays

Wheelchair-mounted rigid trays that are not specifically designed for use during travel in motor vehicles should be:

- Removed and secured separately in the vehicle.
- Secured to the wheelchair so they will not break free in a crash.
- Positioned with a gap of at least 3 in. (7.6 cm) between the back edge of the tray and the wheelchair occupant's abdomen and/or chest so as not to interfere with proper belt-restraint use.
- Fitted with energy-absorbent padding between the back edge of the tray and the wheelchair occupant.

User Safety

The use of a postural pelvic belt attached to the wheelchair base or seat frame is encouraged during travel, but these belts should be positioned so that they do not interfere with the proper positioning of crash-worthy belt restraints, and they should not be relied on for occupant protection in crash situations unless the postural belt has been designed to comply with, and perform to, the requirements 4.6, 5.2, and 5.3 of RESNA WC-4:2012, Section 19.



DANGER

Alterations or substitutions should not be made to the seating system or its parts and components without consulting the manufacturer.



DANGER

The WC20-approved Epic Seating System has been designed to accommodate the proper use of vehicle-anchored belt restraints and the ratings of the seating systems with regard to ease of properly positioning vehicle-anchored belt restraints on the wheelchair passenger, and the degree to which proper positioning of the belt restraints can be achieved.

Sufficient forward and rearward clear space should be provided around the wheelchair occupant.

The forward clear-space (FCZ) needs to be larger when a shoulder-belt restraint is not used.

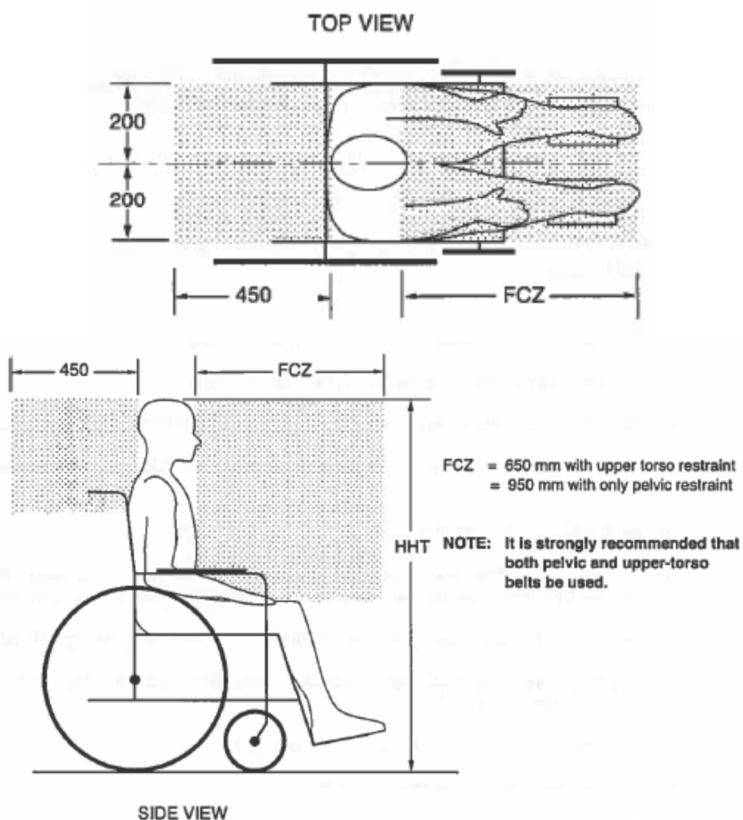

DANGER

The WC20-approved Epic Seating System is designed **ONLY** for use with wheelchair frames that have been successfully crash tested to the frontal impact requirements of RESNA WC-4:2012, Section 19.



DANGER

The WC20-approved Epic Seating System **MUST** be used on a wheelchair frame that provides four securement points and pelvic-belt anchor points that conform to the requirements of RESNA WC-4:2012, Section 19.

First Time Use

Dealer Assistance

During first-time use by the client, it is advised that the dealer or service technician assists and explains the different drive configurations to the customer (the user and/or the attendant). If needed, the dealer can make final adjustments.

SAFETY

Periodically inspect hardware for loose or missing fasteners. Tighten or replace them as necessary.

User Testing

It is important that the customer is fully aware of the installation, how to use it, and what can be adjusted in order to gain as much mobility as possible. As a dealer, proceed as follows:

Explain and show the customer how you have executed the installation, and explain the function of every new item.

Have the user test all positions and functions of the **Epic Seating** system:

- Is the **Epic Seating** system installed according to the client's needs?
- Is the **Epic Seating** system adjusted according to the client's needs?
- Can the client reach all controls and functions of the wheelchair while operating the **Epic Seating** system throughout its range of motion?

If needed, adjust the **Epic Seating** system and retest until the optimal position is found and the system functions properly for the client's needs.

SAFETY

Regularly inspect all covers, cushions and grips for breakdown or abrasion. Replace any worn or damaged parts.

NOTICE

Weight Capacity: 250 lbs (113.4 kg)

Conditions of Use

The **Epic Seating** system is intended for use as installed by the dealer, in accordance with the instructions in this manual.

- The foreseen conditions of use are communicated by the dealer or service technician to the user and/or the attendant during the first-time use.
- If the conditions of use change significantly, please contact your dealer or qualified service technician to avoid excessive wear and tear or unintended damage.

Cleaning

- Use a soft cloth to clean the back shell.
- Ensure all cleaners are approved for finished steel, aluminum, plastic, and upholstered surfaces.
- Hand wash the foam pad cover with mild, soapy water or detergent, rinse well, and let dry.
- Foam pad should **NOT** get wet.
- A brush with soap and water can be used to remove any dirt and debris that may become lodged in the zipper teeth.



WARNING

DO NOT immerse foam in water.
DO NOT Bleach. **DO NOT** tumble dry. **DO NOT** Iron.
DO NOT wash in water temperatures above 160°F (70°C).

To wash the pad covers:

- Remove the pad/cover from the back support and pelvic support cushions; and,
- Machine wash in cold water on delicate cycle and drip dry.

Fabric care instructions can be found on the covers on the cushions and backrest.



CAUTION

Exercise caution when removing the back to avoid punctures, tears, or other damage to the fabric or foam. Be careful not to catch hair, wires or other items when zipping and unzipping the covers.

Disinfection

- Wipe gently with a cloth dampened with a household disinfectant.
- Allow foam to air dry thoroughly.

Maintenance

These care and maintenance instructions will help to prevent damage and keep the hardware and covers in good condition for a longer period of time.

- Check and tighten all fasteners on a regular basis. Do not overtighten the fasteners.
- Check pad/covers for any breakdown.
- Inspect the condition of cables, clamps, and release levers, and the function of the struts.
- Repair or replace parts as needed.
- Gently remove dust and dirt from hardware with a damp cloth as necessary.

Disposal

For scrapping, adhere to your local waste legislation. Recycle parts responsibly, in accordance with local recycling regulations.



© 2023, Stealth Products, LLC

Warranty Information



Home Page



Online User Manual



Stealth Products, LLC · info@stealthproducts.com · www.stealthproducts.com
(800) 965-9229 | (512) 715-9995 | 104 John Kelly Drive, Burnet, TX 78611